

SISTEMA montage handleiding



Sistema QX1



Sistema QX2



Sistema QX3



Sistema QX-L1



Sistema QX-L2

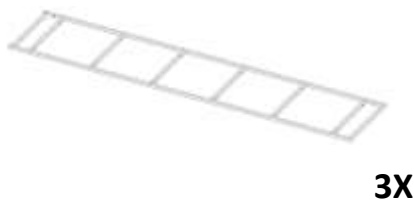

Sistema QX-L3



Sistema RH



Sistema RK

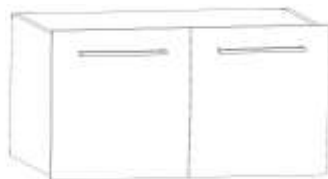

Sistema RL



Sistema RM

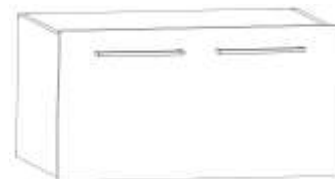



1.

Sistema QX-L1	x 24	 Roundhead imbus bolt M6x30
Sistema QX-L2	x 36	
Sistema QX-L3	x 48	

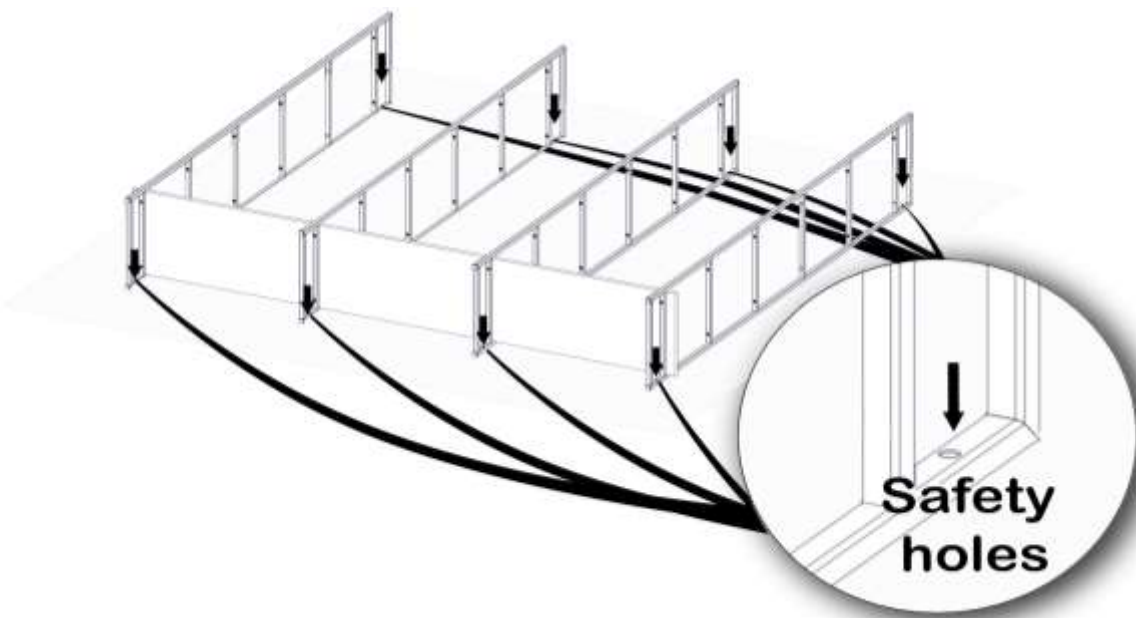
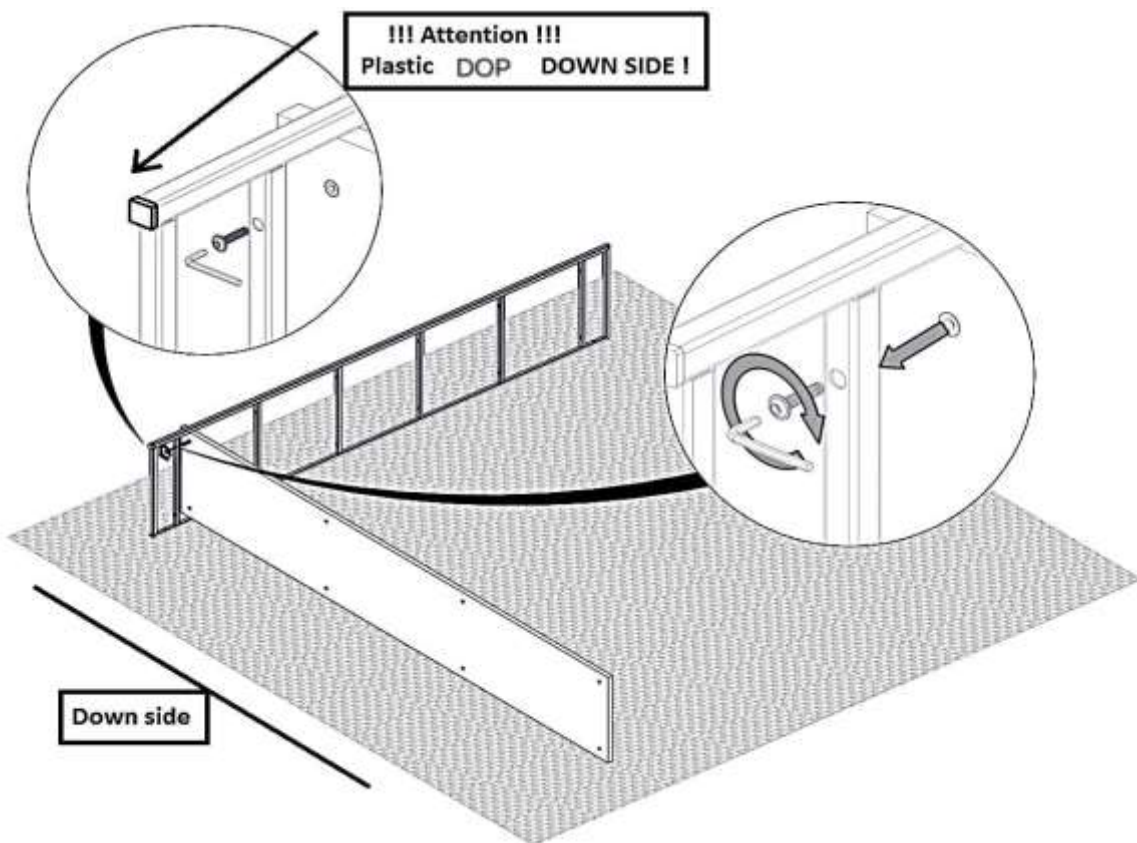

2.

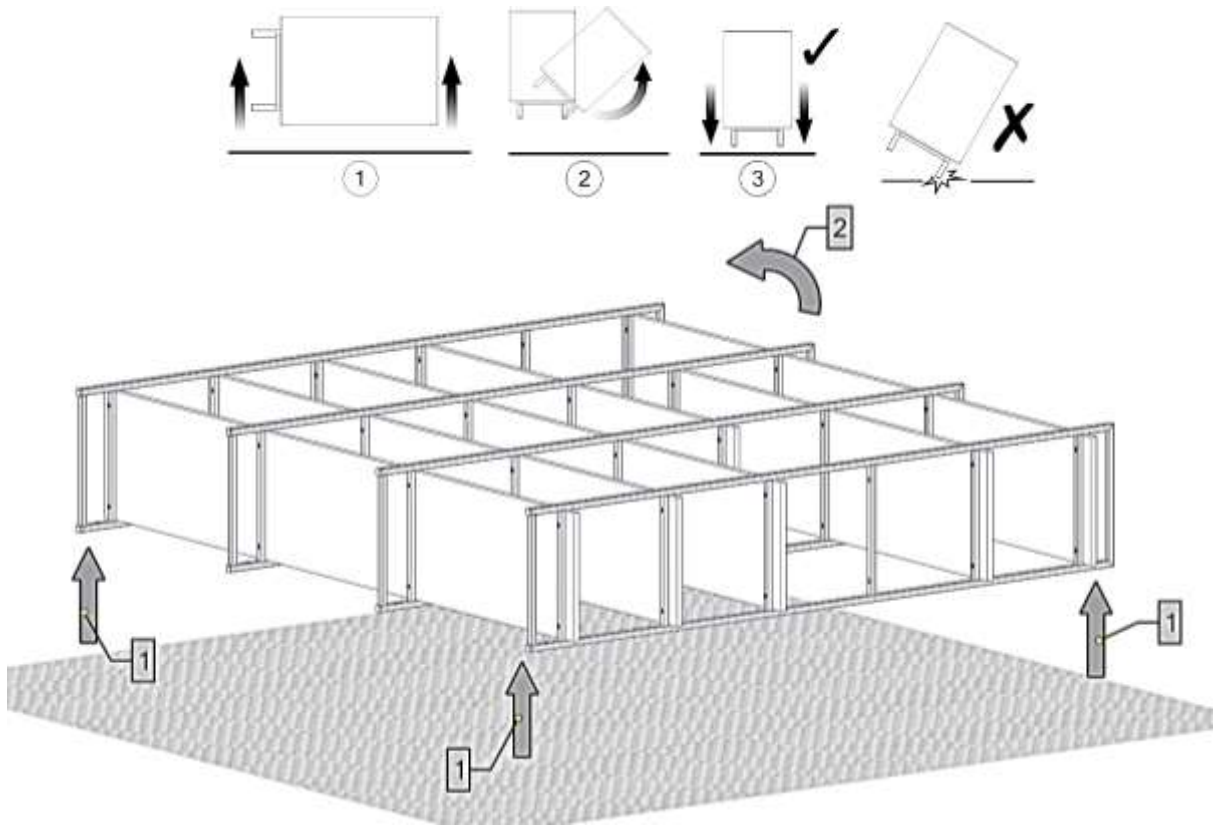

3.

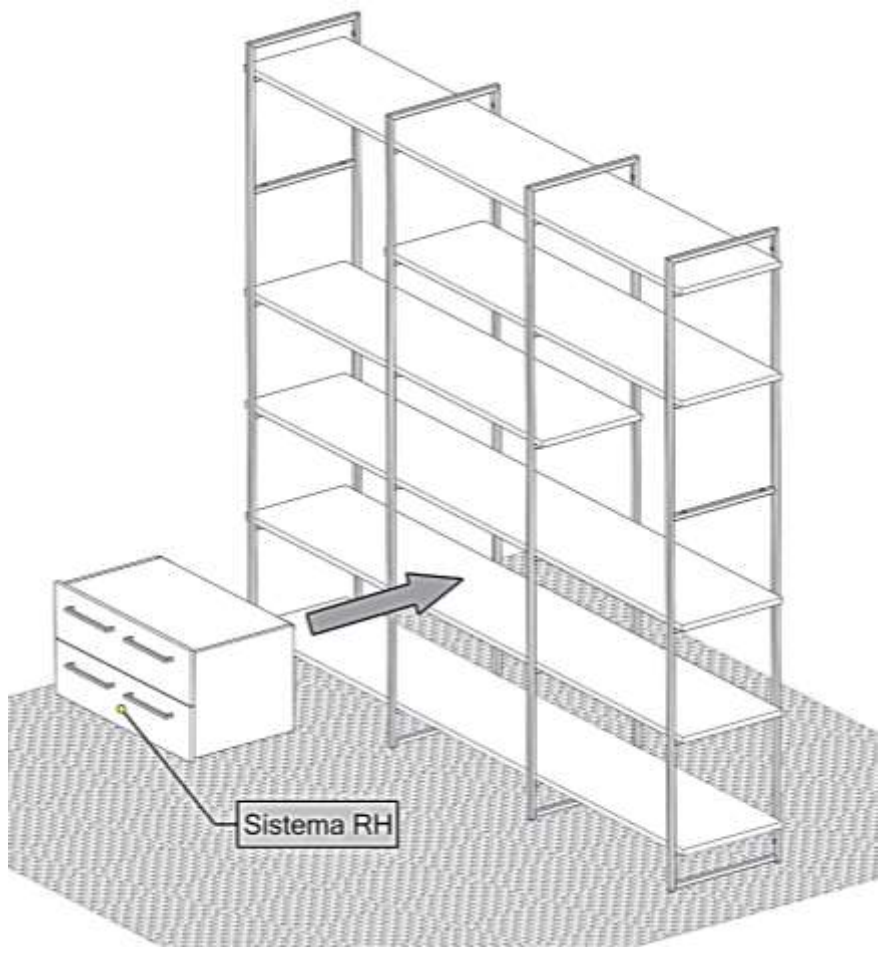

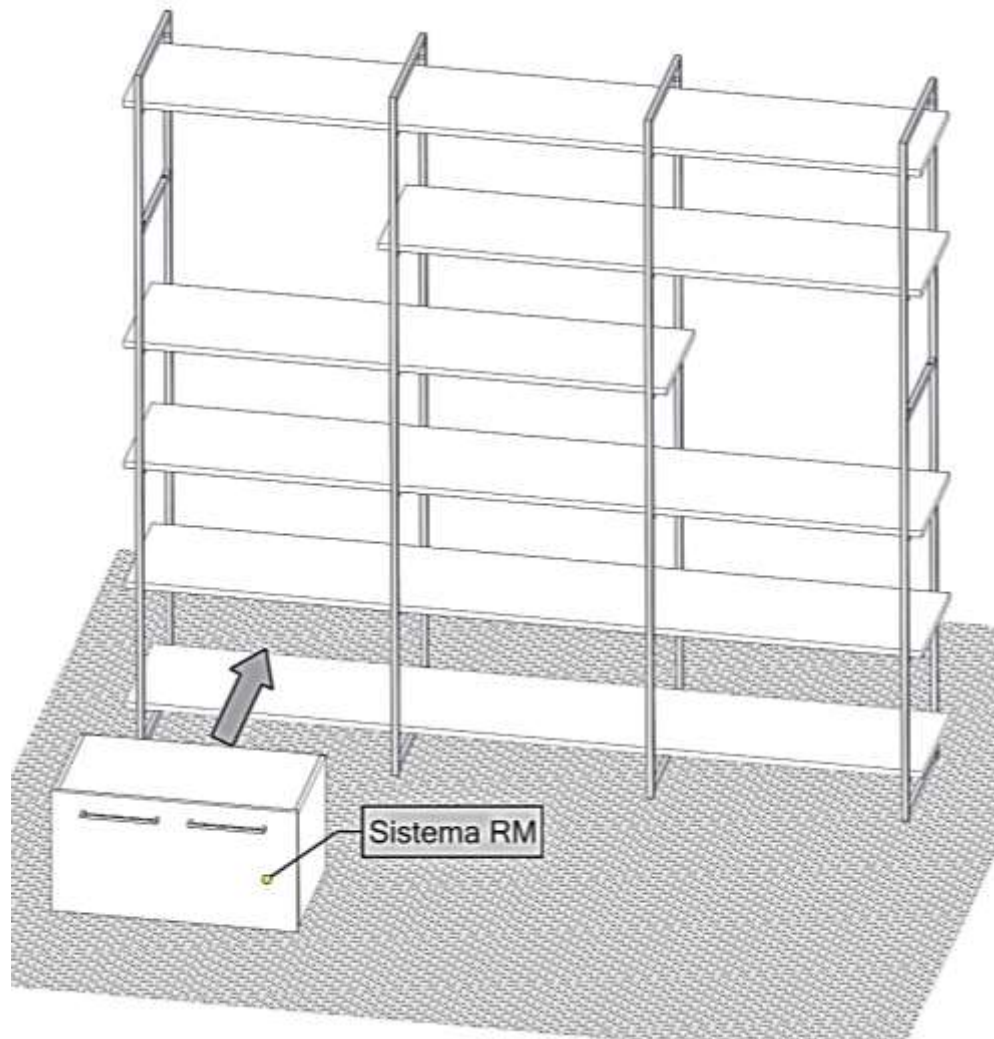
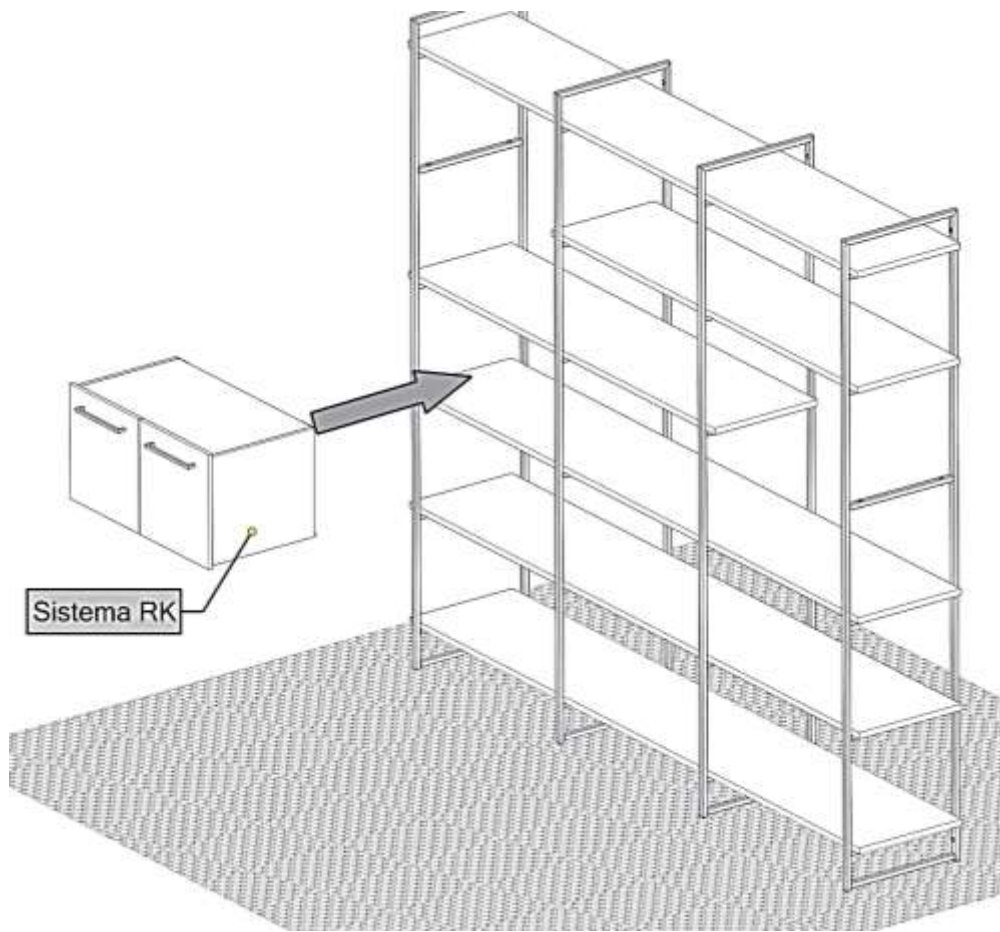

Sistema RL

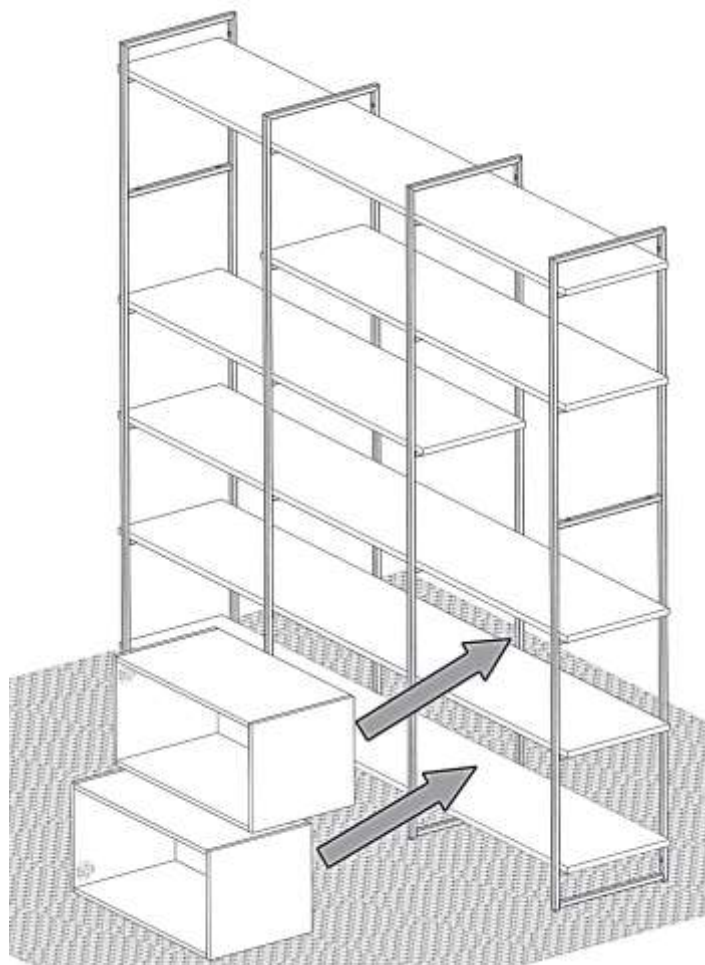
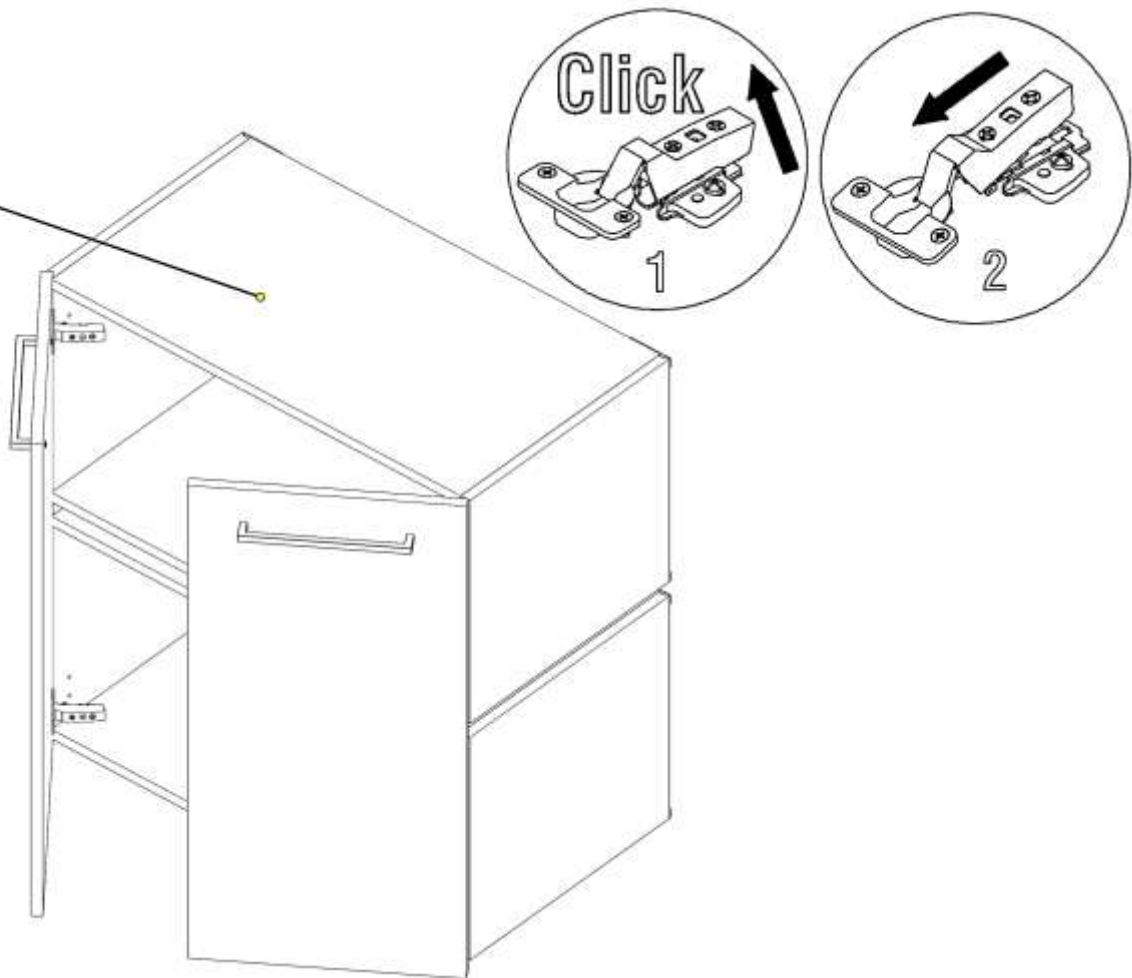

4.

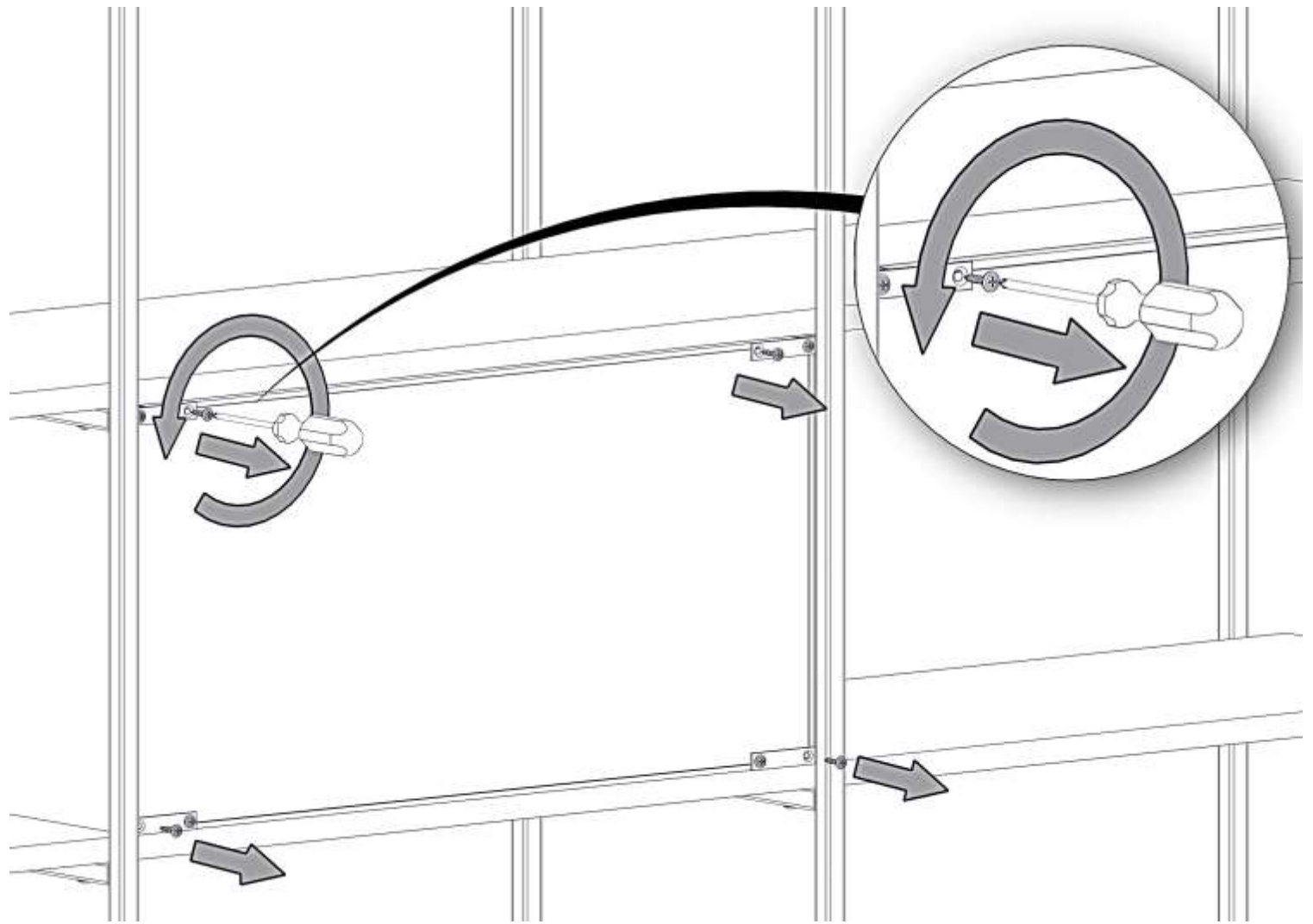

5.

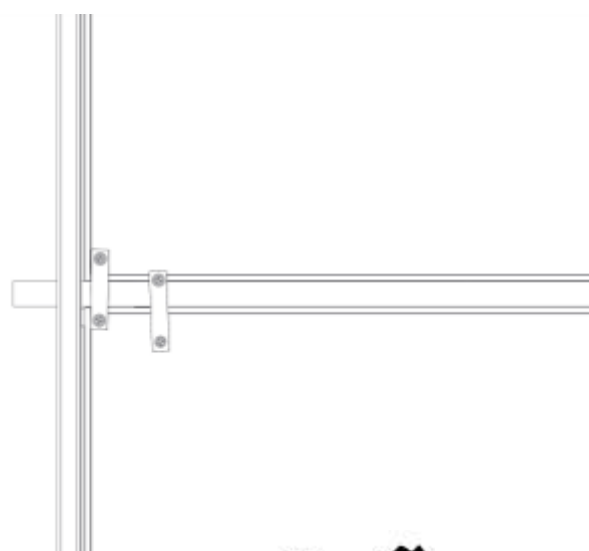
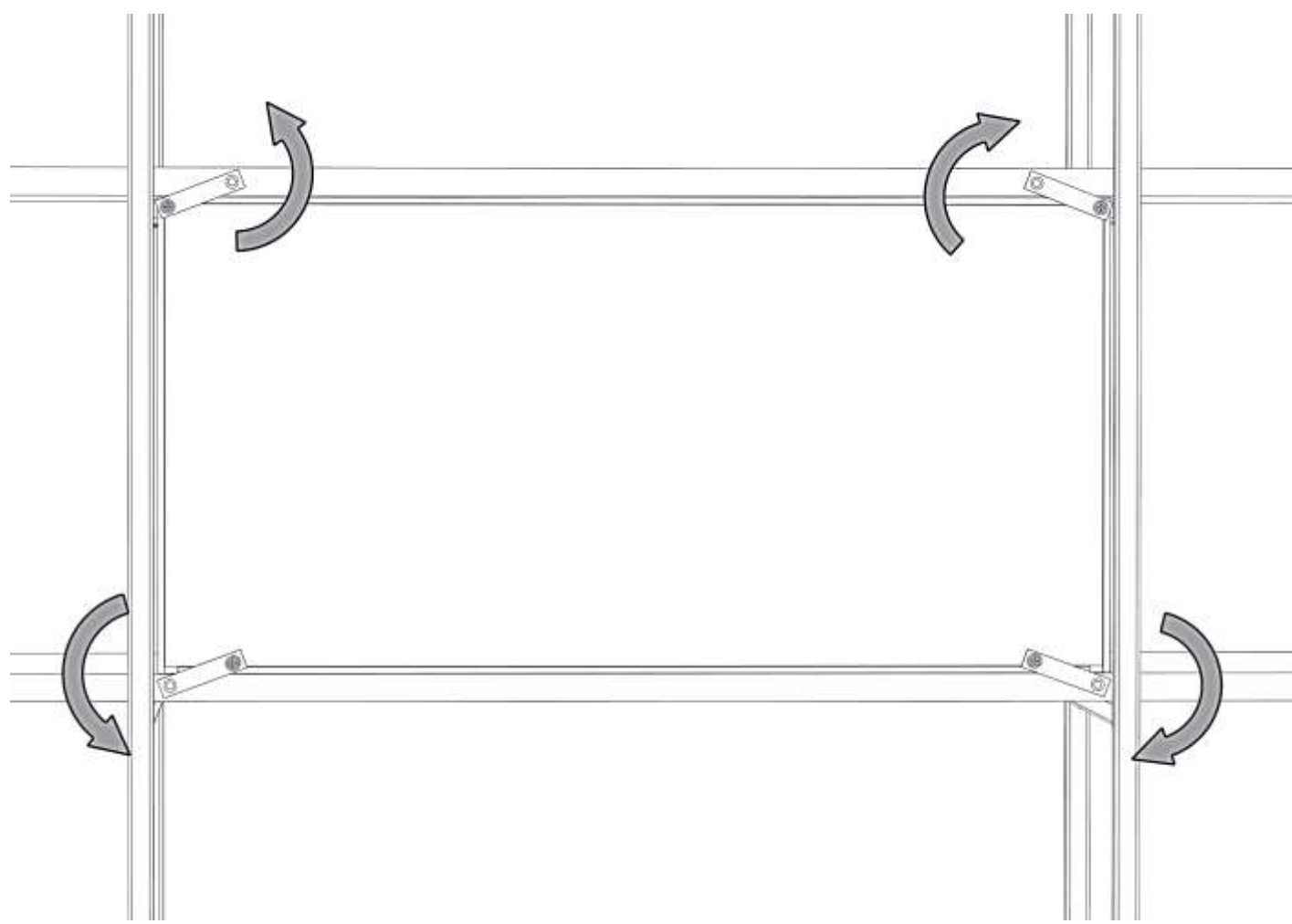

X

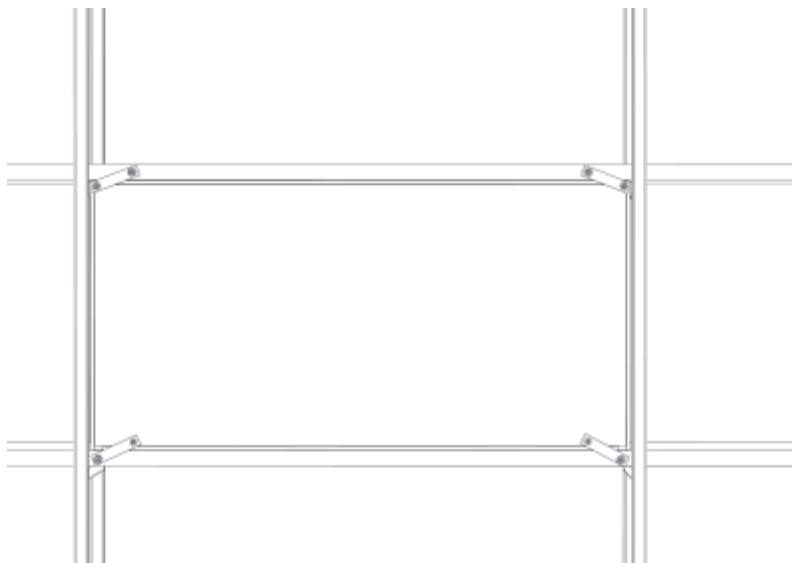

✓

6.

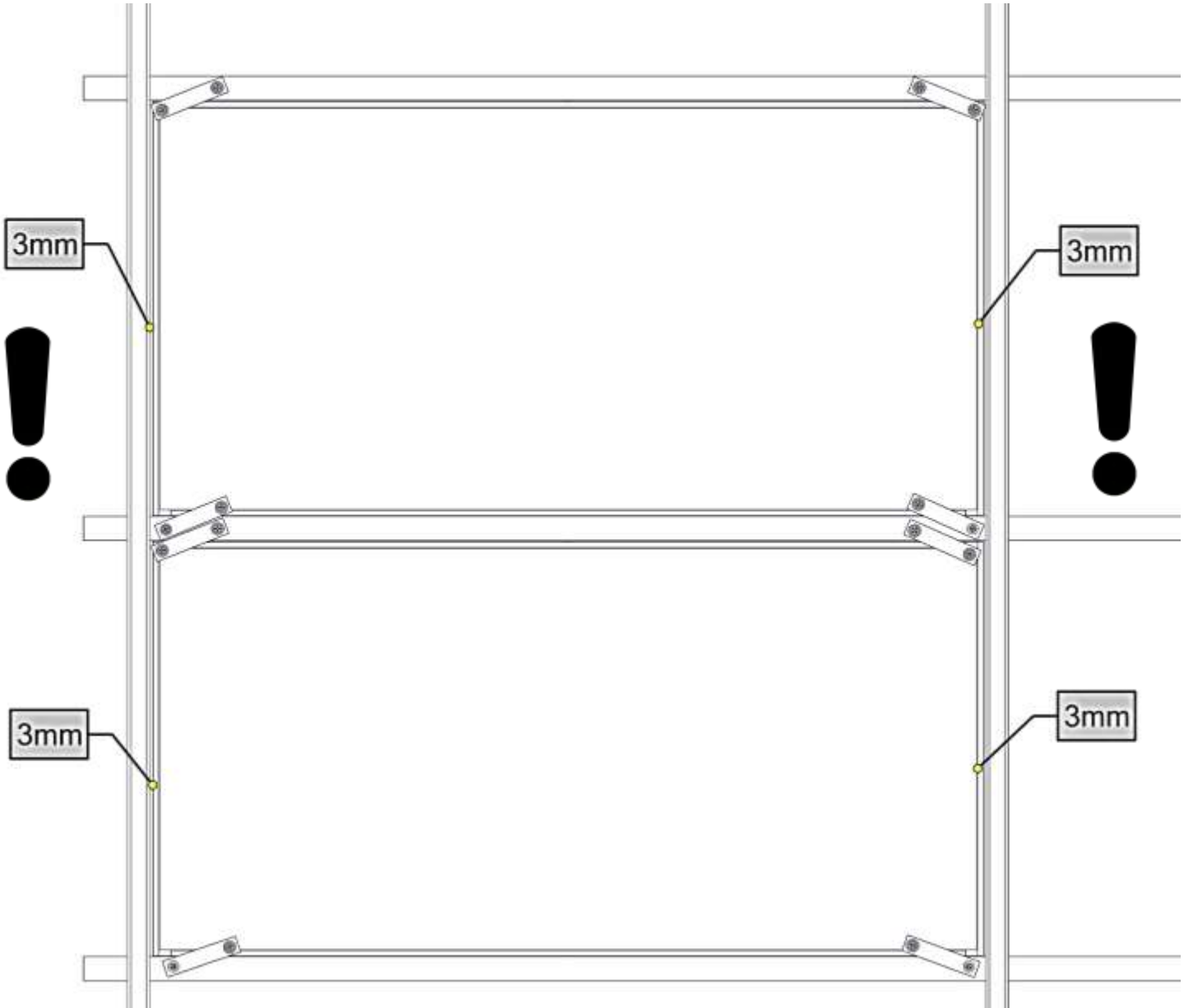

7.

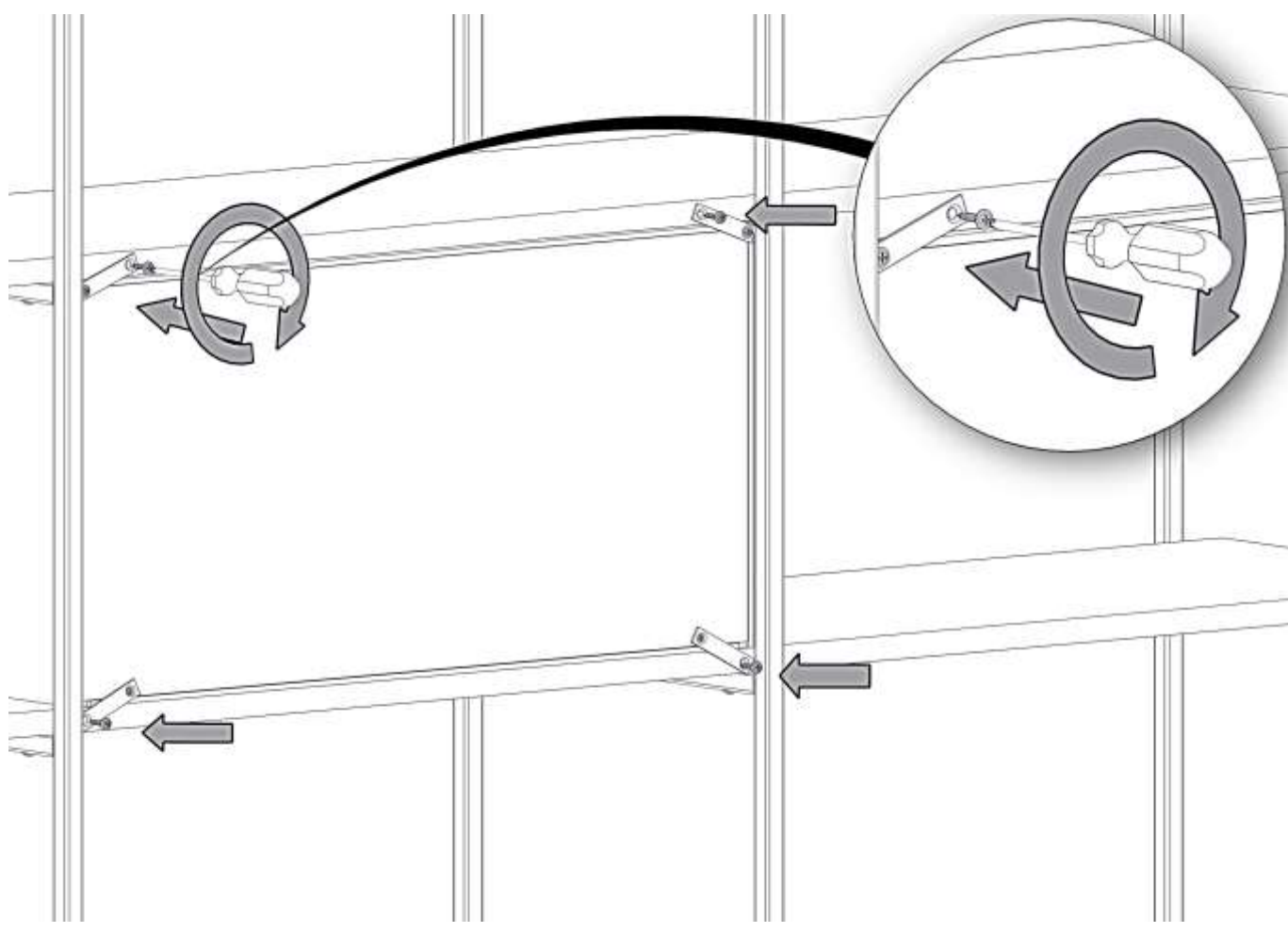

8.

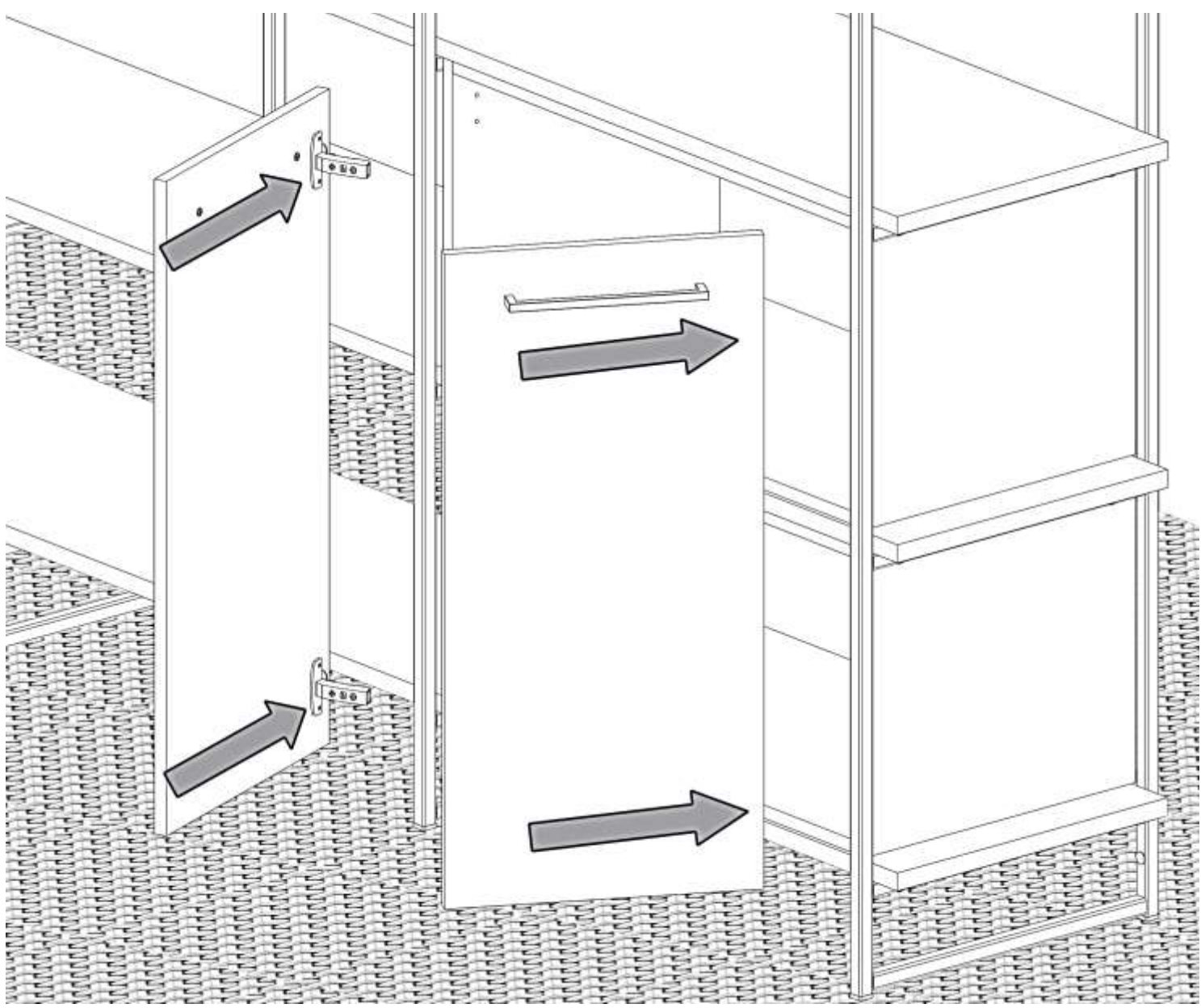

9.

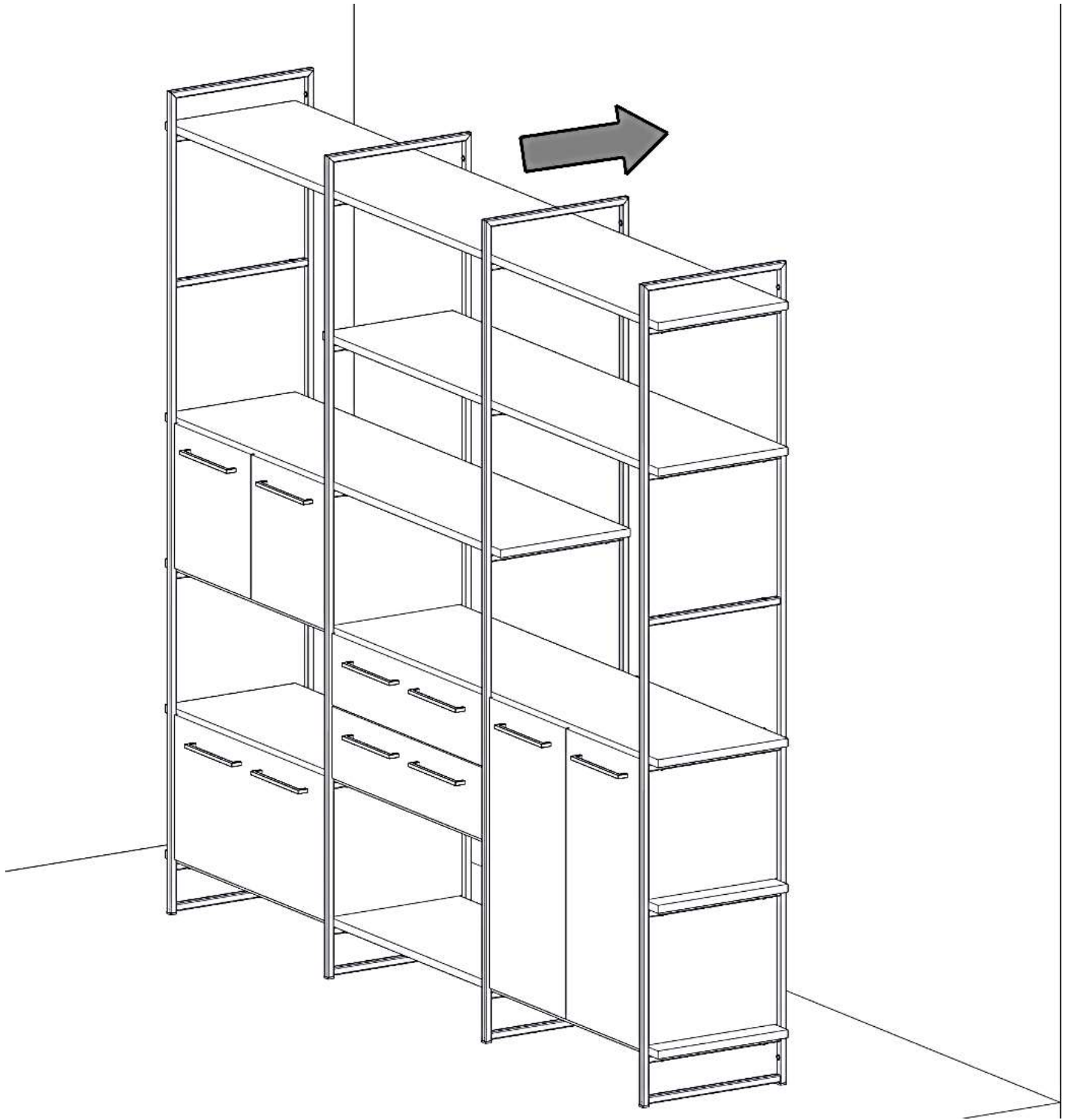

NIET INBEGREPEN / NOT INCLUDED

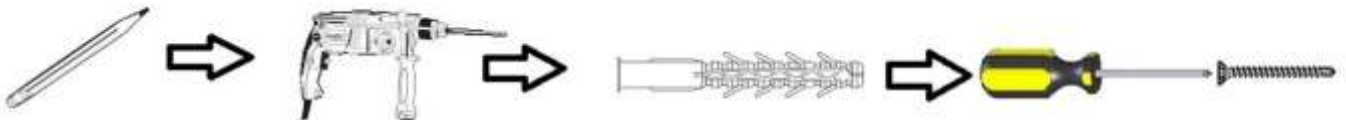

10.

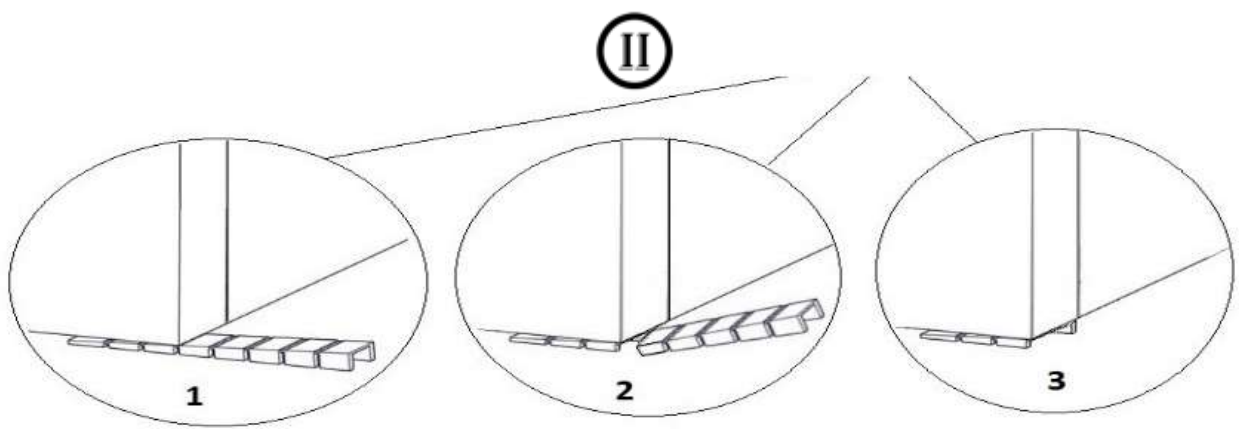
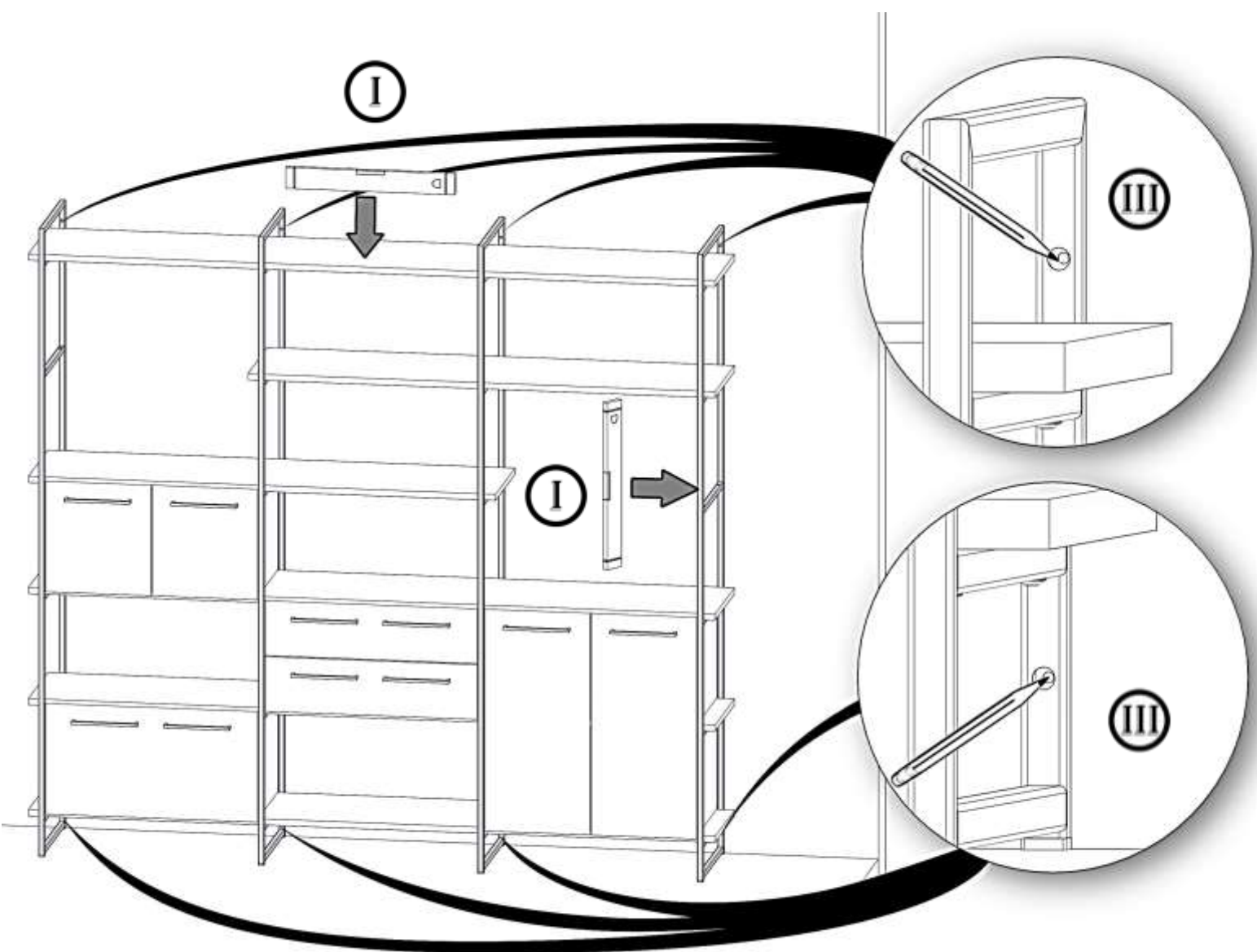

11.

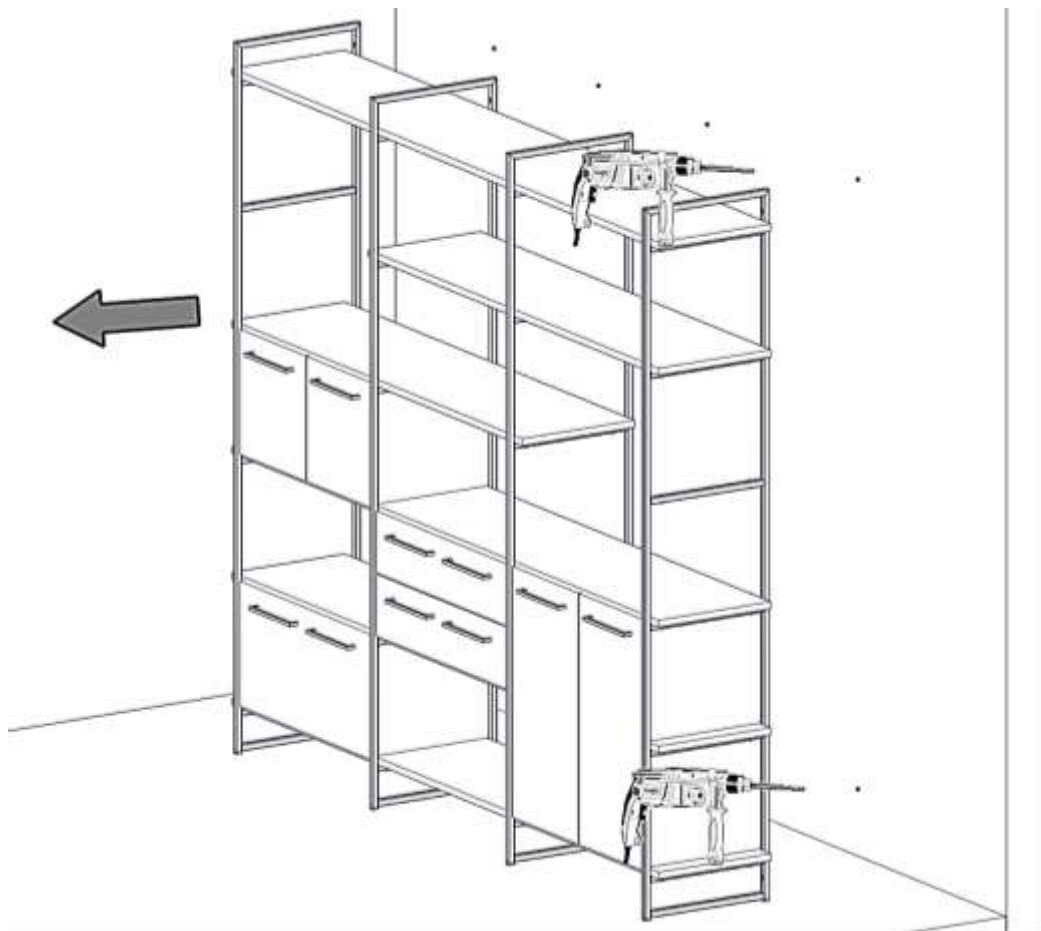

Dringend advies:

Indien u een hoog wandmeubel gekocht heeft, verzoeken wij u het meubel op de gewenste locatie eerst vlak te zetten en het daarna met de voormonteerde strips aan de wand te bevestigen om mogelijk kantelen van de kast en/of om letsel te voorkomen. Pluggen en schroeven voor wandbevestiging zijn niet inbegrepen omdat dit sterk afhankelijk is van het soort wand. Koop deze bij de lokale vakhandel en vraag advies indien nodig. Na het aftekenen en boren (met de juiste boor) de plug plaatsen voordat u de strip vastschroeft. Voorkom foutieve montage en mogelijke schade of letsel.



ACIS URGENT

Si vous avez acheté un meuble haute, nous vous conseillons de d'abord ajuster le meuble au sol et de le fixer avec les strips prémonté au mur pour empêcher le meuble de reverser et causer des blessures éventuelles. Des bouchons et vises pour attacher le meuble au mur ne sont pas livré avec par ce qu'il est important d'utiliser des vises adapté au type de mur. Achetez les chez votre détailliste spécialisé et demander son avis. après signalisation et perçage (avec la perceuse adequate au mur), veuillez utiliser une fiche pour viser correctement le strip. évitez une montage incorrecte et endommagement et blessures possibles.



Dringende Ratschläge:

Wenn Sie eine hohe Wandeinheit haben, bitten wir Sie, die Möbel zuerst an der gewünschten Stelle auszurichten und sie dann mit den vormontierten Leisten an der Wand zu befestigen, um ein Kippen des Schrankes und / oder um Verletzungen zu vermeiden. Stecker und Schrauben für die Wandmontage sind nicht enthalten, da dies stark vom Wandtyp abhängt. Kaufen Sie sie im örtlichen Einzelhandel und lassen Sie sich gegebenenfalls beraten. Platzieren Sie nach dem Markieren und Bohren (mit dem richtigen Bohrer) den Stecker, bevor Sie die Leiste anschrauben. Vermeiden Sie eine falsche Installation und mögliche Schäden oder Verletzungen.



Urgent advice:

If you have bought a high wall cabinet, we ask you to first flatten the furniture at the desired location and then fix it to the wall with the pre-assembled strips. This to prevent possible tilting of the cabinet and preventing anyone to get injured. Plugs and screws for mounting the cabinet to the wall, are not included because the kind of plugs and screws you need is depending on the type of wall. We recommend to buy it from your local hardware store and ask for advice if necessary. After drawing and drilling (with the right drill), place the plug before screwing the strip. Prevent incorrect assembly or injury of any kind.

12.

NIET INBEGREPEN / NOT INCLUDED

 x4 / 6 / 8 pcs.

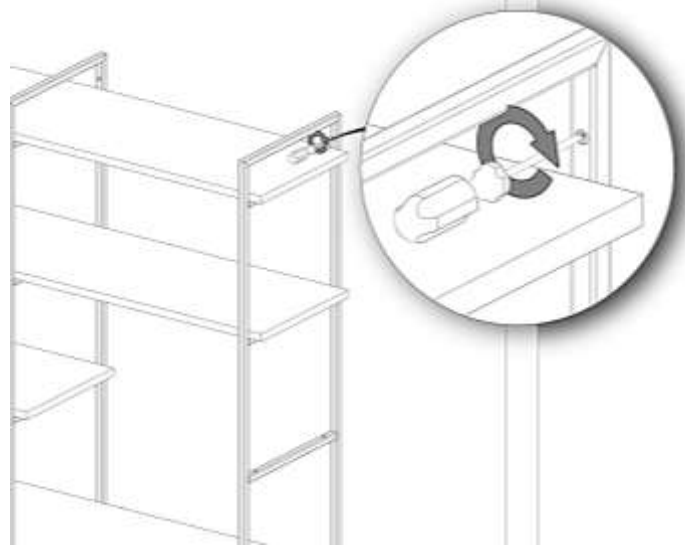
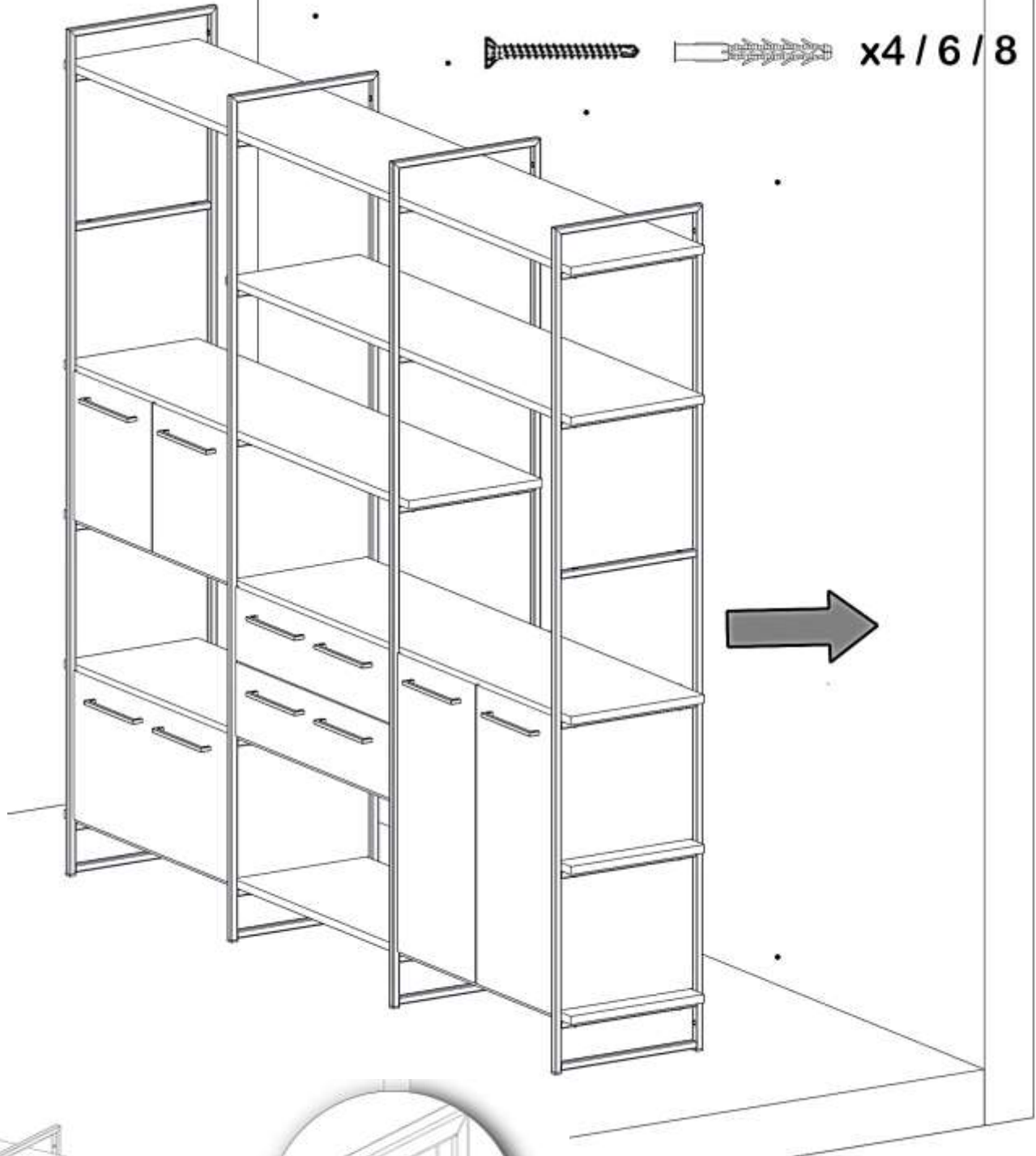

13.

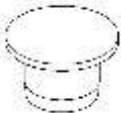
Sistema QX-L1	x 24		Round plastic cap $\varnothing 10$
Sistema QX-L2	x 36		
Sistema QX-L3	x 48		

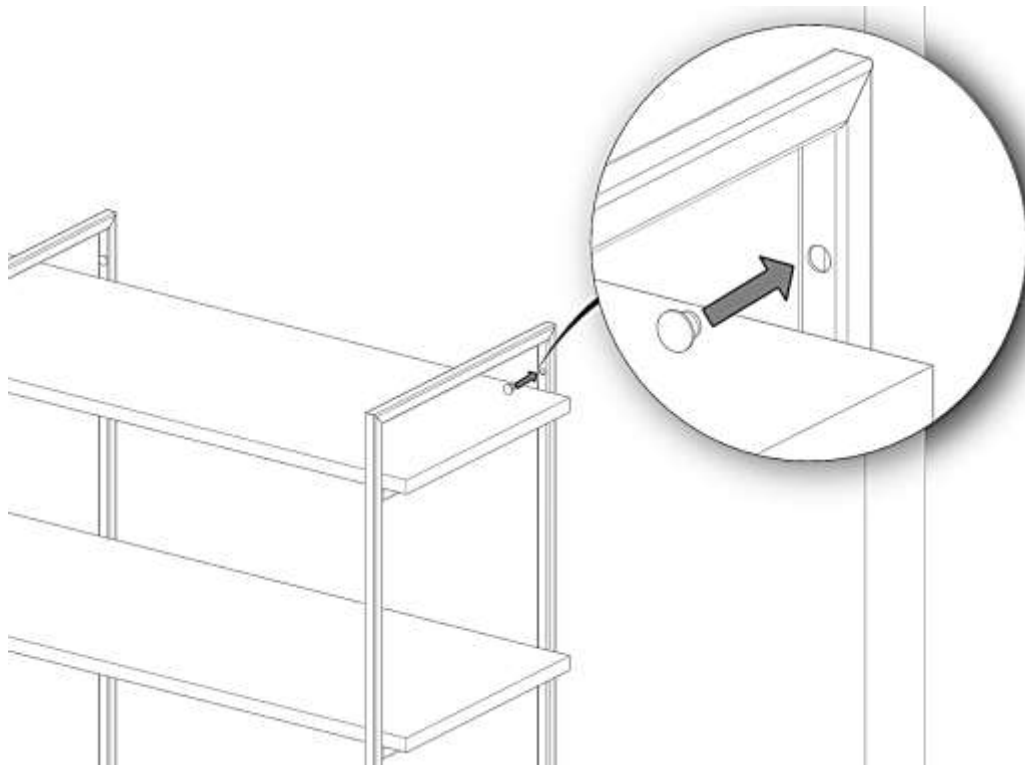
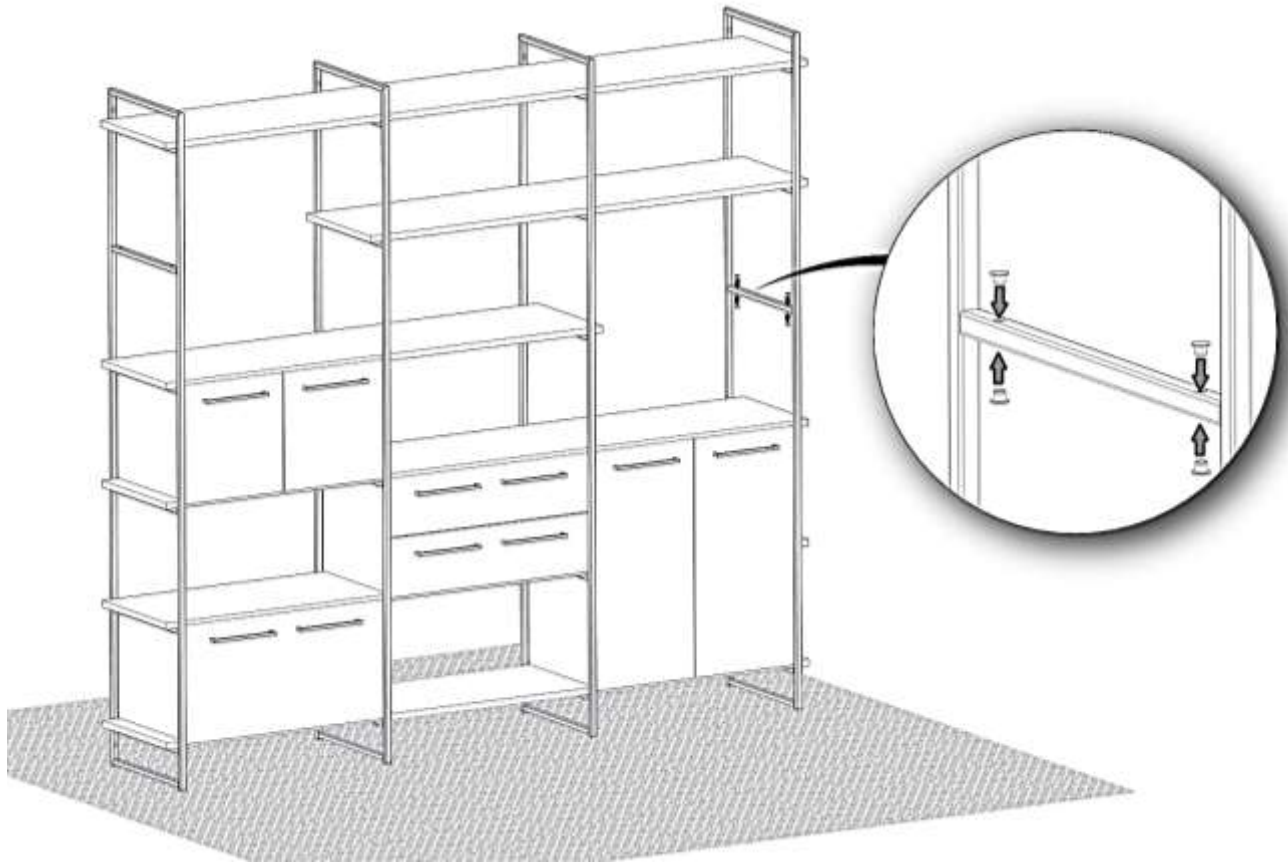



Mogelijke deur afstelling:

Indien nodig kan de deur ge(de-)monteerd worden en/of kan de positie in hoogte, breedte en diepte iets veresteld worden. Zie onderstaande aanwijzingen.



RÉGLAGE DES PORTES

Si besoin, il est possible de régler la position des portes dans la hauteur, largeur et profondeur. veuillez voir ci-dessous.



Mögliche Türeinrichtung:

Wenn nötig kann die Tür (de)montiert werden und / oder die Position kann in Höhe, Breite und Tiefe etwas angepasst werden. Siehe die Anweisungen unten.



Possible assembling of the door:

If necessary the door can be (dis)assembled or the position can be adjusted in height, width or depth. See the instructions below.

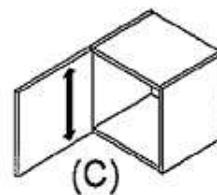
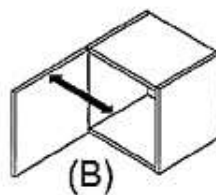
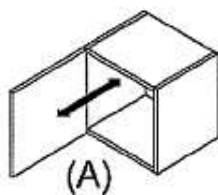
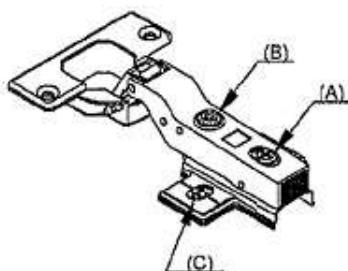
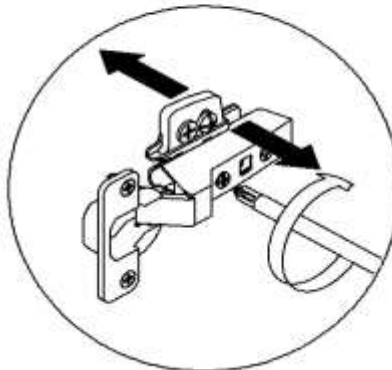
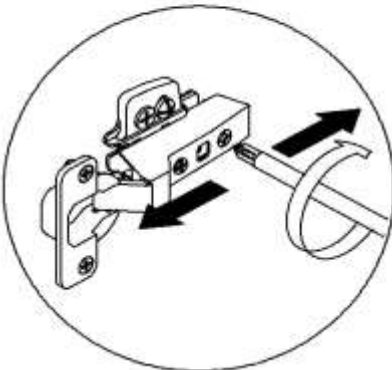
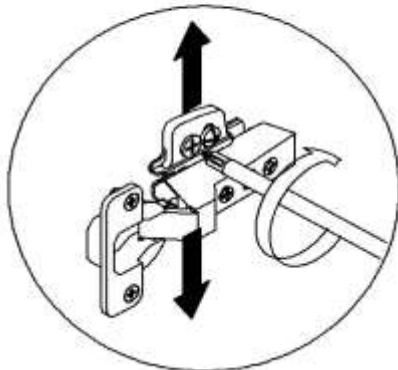



Mogelijke lade afstelling:

Indien nodig kan het ladefront iets (links en/of rechts) in hoogte versteld worden. Draai het borgschroefje aan de onderzijde van de ladebak iets los en verdraai het stelwielje in gewenste hoogte om vervolgens het borgschroefje weer vast te draaien.



RÉGLAGE DES TIROIRS.

Si besoin il est possible d'ajuster la position du tiroir dans la hauteur (gauche ou droite).

Détournez la vis de blocage en bas du tiroir et tourne la petite roue dans la hauteur désirée, puis fixer la vis de blocage. voir dessins ci-dessous



Mögliche Schubladeneinstellung:

Wenn nötig kann die Schubladenfront etwas in der Höhe (links und / oder rechts) eingestellt werden. Lösen Sie die Feststellschraube an der Unterseite der Schublade etwas und drehen Sie das Einstellrad leicht auf die gewünschte Höhe, um die Feststellschraube danach wieder festzuziehen.



Possible assembling of the drawer:

If necessary the drawerfront can be adjusted (left and/or right) in height. Loosen the locking screw on the underside of the drawer slightly, turn the adjusting wheel to the required height and then tighten again the locking screw

